



Work In Progress: Large Scale Development and Deployment of Concept Questions in Statics

Prof. Carisa H Ramming P.E., Oklahoma State University

Carisa Ramming is a graduate of Oklahoma State University where she obtained degrees in Architectural Engineering and Civil Engineering Construction Management. She worked in industry for six years as licensed engineer and structural consultant in Tulsa, OK before returning to Oklahoma State as a visiting faculty member in the School of Architecture. In 2009, Professor Ramming joined the faculty full time as an assistant professor of architectural engineering. Since that time, she has taught classes in structural analysis, timber and steel design, engineering mechanics: statics, building foundations and numerical analysis.

Prof. Christopher Papadopoulos, University of Puerto Rico, Mayaguez Campus

Christopher Papadopoulos is Professor in the Department of Engineering Sciences and Materials at the University of Puerto Rico, Mayaguez Campus (UPRM). He earned B.S. degrees in Civil Engineering and Mathematics from Carnegie Mellon University (1993) and a Ph.D. in Theoretical and Applied Mechanics at Cornell University (1999). Prior to UPRM, Papadopoulos served on the faculty in the Department of Civil engineering and Mechanics at the University of Wisconsin, Milwaukee.

Papadopoulos has diverse research and teaching interests in structural mechanics and bioconstruction (with emphasis in bamboo); appropriate technology; engineering ethics; and mechanics education. He has served as PI of several NSF-sponsored research projects and is co-author of *Lying by Approximation: The Truth about Finite Element Analysis*. He is active in the Mechanics Division.

Eric Davishahl, Whatcom Community College

Eric Davishahl holds an MS degree in mechanical engineering and serves as associate professor and engineering program coordinator at Whatcom Community College. His teaching and research interests include developing, implementing and assessing active learning instructional strategies and auto-graded online homework. Eric has been a member of ASEE since 2001. He currently serves as awards chair for the Pacific Northwest Section and was the recipient of the 2008 Section Outstanding Teaching Award.

Dr. Brian P. Self, California Polytechnic State University, San Luis Obispo

Brian Self obtained his B.S. and M.S. degrees in Engineering Mechanics from Virginia Tech, and his Ph.D. in Bioengineering from the University of Utah. He worked in the Air Force Research Laboratories before teaching at the U.S. Air Force Academy for seven years. Brian has taught in the Mechanical Engineering Department at Cal Poly, San Luis Obispo since 2006. During the 2011-2012 academic year he participated in a professor exchange, teaching at the Munich University of Applied Sciences. His engineering education interests include collaborating on the Dynamics Concept Inventory, developing model-eliciting activities in mechanical engineering courses, inquiry-based learning in mechanics, and design projects to help promote adapted physical activities. Other professional interests include aviation physiology and biomechanics.

Prof. Sinéad C MacNamara, Syracuse University

Sinéad Mac Namara is a structural engineer and Associate Professor teaching in both the School of Architecture and the College of Engineering of Syracuse University. She studied civil and structural engineering at Trinity College Dublin and Princeton University. Her research is concerned with structural art, shell structural design, alternate pedagogies for interdisciplinary education, and investigations to foster creativity and innovation in engineering curricula. Mac Namara co-authored a book *Collaboration in Architecture and Engineering* released in 2014 and her research has been published in engineering and architecture education journals, nationally and internationally. She has received awards for innovative teaching from Princeton University, Syracuse University, and the American Society for Engineering



Education. She also engages in design and design-build projects as a collaborator with her architecture students and colleagues. This work has been recognized with awards from the Association of Collegiate Schools of Architecture, the Architectural Institute of America and the City of New York.

Dr. Meredith Silberstein, Cornell University

Prof. Joan V. Dannenhoffer P.E., Syracuse University

Joan Dannenhoffer is Associate Teaching Professor of Civil and Environmental Engineering at Syracuse University. She received her M.S. in Environmental Engineering from the University of Connecticut and M.B.A. and B.S. in Civil Engineering from Rensselaer Polytechnic Institute. She is a Professional Engineer in the State of Connecticut. Her research interests are in engineering education pedagogy, especially in implementing active learning strategies in large classes. She currently teaches Engineering Statics, Mechanics of Solids, Introduction to Engineering, Civil Engineering Materials, and Intro to Sustainability for Civil and Environmental Engineers.

Large Scale Development and Deployment of Concept Questions in Statics

Introduction:

Students studying basic mechanics are extremely diverse in their mechanics preparation and many struggle with introductory concepts. Historical problem solving methods utilized in studying and learning often times leads to memorization of a process, overlooking the fundamental building blocks necessary for follow on courses. Just as all students are diverse and do not learn in the same manner, instructors vary in their resources and teaching beliefs (Koretsky et al. 2019).

Not surprisingly, for more than three decades, mechanics educators have been aware that even students who perform well on quantitative and procedural exercises often fail to demonstrate understanding of the underlying concepts (Clement 1982)(McDermott 1984)(Halloun and Hestenes 1985b, 1985a)(Mazur 1992). As a result, *concept-based learning* has evolved as an active-learning approach to address this situation. According to (Koretsky et al. 2019),

Concept-based active learning is the use of activity-based pedagogies whose primary objectives are to make students value deep conceptual understanding (instead of only factual knowledge) and then to facilitate their development of that understanding. It has been shown to increase academic engagement and student achievement (Freeman et al. 2014), to significantly improve student retention (National Academies of Science, Engineering, and Medicine 2011), and to reduce the performance gap of underrepresented students (Haak et al. 2011).

Although concept-based pedagogies are effective, “[c]reating effective [concept] questions is difficult and differs from creating exam and homework problems” (Beatty et al. 2006), and there is currently a lack of readily-available concept questions designed for classroom use. Existing concept inventories (CI’s), such as the Concept Assessment Tool for Statics (“CATS”) (Steif & Dantzer, 2005) consist of a relatively small number of questions (the CATS has 27), limiting the variety of questions that can be posed for a given concept. Moreover, in-class feedback and discussion threaten the overall security of such an instrument that has a small number of questions. Finally, CI questions have single correct answers, limiting their use to motivate exploration and discussion of situations with multiple possible defensible answers and interpretations.

For concept-based instruction to be scaled up, a large repository of questions that can be broadly and efficiently deployed is needed. To this end, the authors are part of a project currently funded by NSF to expand the Concept Warehouse (CW), an existing online depository of concept questions called “ConcepTests” (initially developed for Chemical Engineering topics), to build new ConcepTests for Statics, Dynamics, and Mechanics of Materials. The CW can be used to develop and deploy questions to students via multiple modalities (in class, at home, online, offline, etc.), and it is also relatively easy for instructors to create their own questions nearly in real time. To date, approximately 140 Statics questions have been developed, and will expand to about 200 by the time of the Conference & Expo. A summary of question design philosophy, scope, and examples are provided in this paper, which will focus primarily on the implementation in engineering mechanics statics courses.

In order to build a diverse repository that will fit the needs of many instructors and students, the project comprises five institutions that cover a wide range of institutional contexts: Cal Poly San Luis Obispo (a large non-PhD granting public university, and the lead institution); Oregon State University (a large research public university); Bucknell University (a small private university); Allan Hancock College (a 2-year college serving a large number of under-represented students); and the University of Puerto Rico, Mayagüez (a public, bilingual research university). In addition to these principal institutions, other institutions are involved due to participation of colleagues as developers and/or deployers of ConcepTests (these colleagues were recruited based on their participation in ASEE and demonstrated use of evidence-based pedagogies). Oklahoma State University and Whatcom Community College are both playing key roles in developing and deploying ConcepTests for Statics, and results from these institutions constitute the primary focus of this paper.

Concept Warehouse Development and Design Philosophy

As proposed, the project to develop the CW is based on the following operational design principles:

- **Question Quality Principle:** Provide faculty a resource of high quality conceptual questions.
- **Question Quantity Principle:** Provide a large enough question pool so that instructors can find questions pertaining to the specific concept they are teaching.
- **Emergent Use Principle:** Provide versatility in how questions can be deployed in instruction so that instructors can use them in ways that best fit their beliefs and context.
- **Familiarity Principle:** As much as possible, design the layout of the website to be intuitive and match other common web sites with which users may be familiar.
- **Support Principle:** Provide multiple ways to technically support faculty who adopt the tool. Such support can be online resources, webinars, workshops, and email.
- **Community Contribution Principle:** Provide a way for faculty to contribute their own materials and to participate as peer reviewers of content.
- **Data Collection Principle:** Collect question response data for instructors to use in class and to provide empirical evidence to characterize questions and identify student misconceptions.

After the project was funded, in early 2019, the project team met to discuss creating ConcepTests and to develop the overall workplan. At this meeting, a basic question design philosophy was introduced such that each question should have a stated *content goal* (which topic is intended to be understood?), *process goal* (which cognitive skill or skills will be exercised?), and *epistemological goal* (what larger ideas about understanding the nature of doing engineering will be elicited?), following (Beatty et al. 2006). Within this framework, ConcepTests are typically qualitative and require no or very minimal numerical calculation, although they may require mental imagination of the development of key equations. Also, some ConcepTests are intended for summative assessment and should follow specific guidelines; others may be open-ended and intended to provoke debate and force students to verbalize and justify their assumptions when answering questions (Beatty et al. 2006).

Since the workshop, the team has had virtual meetings every 1-2 months to discuss concept question development and to review progress. A systematic review process was set up to provide feedback on all of the different questions, and to plan and manage initial student testing conducted at three different institutions. During this developmental period, two issues of problem development have emerged as they relate to the overall philosophy. First, it is relatively difficult to cleanly articulate the process and epistemological goals for each question, and the team is currently attempting to develop a set of universal goal statements that can be applied to all problems; this is still in progress. Second, the team members tend to gravitate toward questions that have unambiguously correct or incorrect answers; a challenge for the team is to develop more questions that are intentionally designed to have multiple defensible solutions.

Regarding administration of the ConcepTests, they are deployed and accessed free of charge through the Concept Warehouse. The CW has been highly successful in the Chemical Engineering community, and is now expanding into the mechanics community. The CW is very flexible in its use and can be deployed on laptop computers, tablets, and phones; it is also compatible with different operating systems. Faculty can assign questions online before class, as homework, during class where the CW can be used as a classroom response system, or as downloaded questions to be used on quizzes or tests. The CW is compatible with the learning management system Canvas, although full functionality is still in process. Work on developing compatibility with other LMS is ongoing.

During the Fall of 2019, the CW for Statics was beta tested at Whatcom Community College and at Oklahoma State University. For Spring 2020, the CW will continue to be used at the two initial institutions and also at the University of Puerto Rico, Mayagüez. In total, up to 600 students are expected to be impacted during this initial trial.

Concept Warehouse:

The CW provides an instructor with thought-provoking questions that will guide students to answers within a few minutes without burdensome calculations. The current concept question bank for statics contains 140 questions, and up to 200 are anticipated by summer 2020. The topic list follows the usual contents of a standard Statics textbook: Vectors, Particle Equilibrium, Moments, Rigid Body Equilibrium, Trusses, Frames and Machines, Internal Forces, Friction, Centroids, and Moment of Inertia. Instructors can filter questions by topic and view concept question goals (content, process, and epistemological) (Figure 1). Instructors may use ConcepTests in real time during class or assign them as out-of-class activities. They may also add prompts for a short answer response, rationale, or a confidence rating (Figure 2). After deployment, instructors can view detailed student results and feedback, and show these to the class to motivate further discussion and inquiry (Figure 3).

3D Moments 1

The object is supported by a pin support mounted to a wall in the xz plane. Consider the moment about the pin at A due to the weight force W . Which answer correctly describes the direction of this moment vector?

General Information

Contributor: [University of Michigan](#)

Author: [John Hestenes](#)

Class: Statics

Type: Multiple Choice

Usage

Instructors used: 0

Times used: 0

Institutions used: 0

Rating

☆☆☆☆☆

Difficulty index: 0

Answers/Author Comments

Content goal: Understand moments and how to represent moment vectors in Cartesian components.

Process goal: Visualize the moment (scalar approach in 3D or cross product) and use the right-hand rule to visualize the direction of the moment vector.

Epistemological Goal: Develop reasoning and visualization skill to predict and verify numerical calculations.

Choice	Correct	Comment
positive x , positive y , and positive z directions.	<input type="checkbox"/>	
negative x , positive y , and positive z directions.	<input type="checkbox"/>	
negative x and positive y directions only.	✓	
negative z direction only.	<input type="checkbox"/>	Common misconception that direction of moment is tangent to the arc traced by the body if it were to actually rotate.

Figure 1: Sample ConcepTest from the Concept Warehouse.

Label (visible to students):

Add short answer followup.
 Add confidence followup.
 Add question-effectiveness followup.

Assign - Manual Stop

Assign - Timed Test Stop in: 5 minutes

Assign - Homework Start: 2020-02-17 08:00:00
 Due: 2020-02-21 08:00:00
 Timezone: (GMT-06:00) Central Standard Time (US & Canada)

Cancel

Figure 2: Question settings for a ConcepTest.

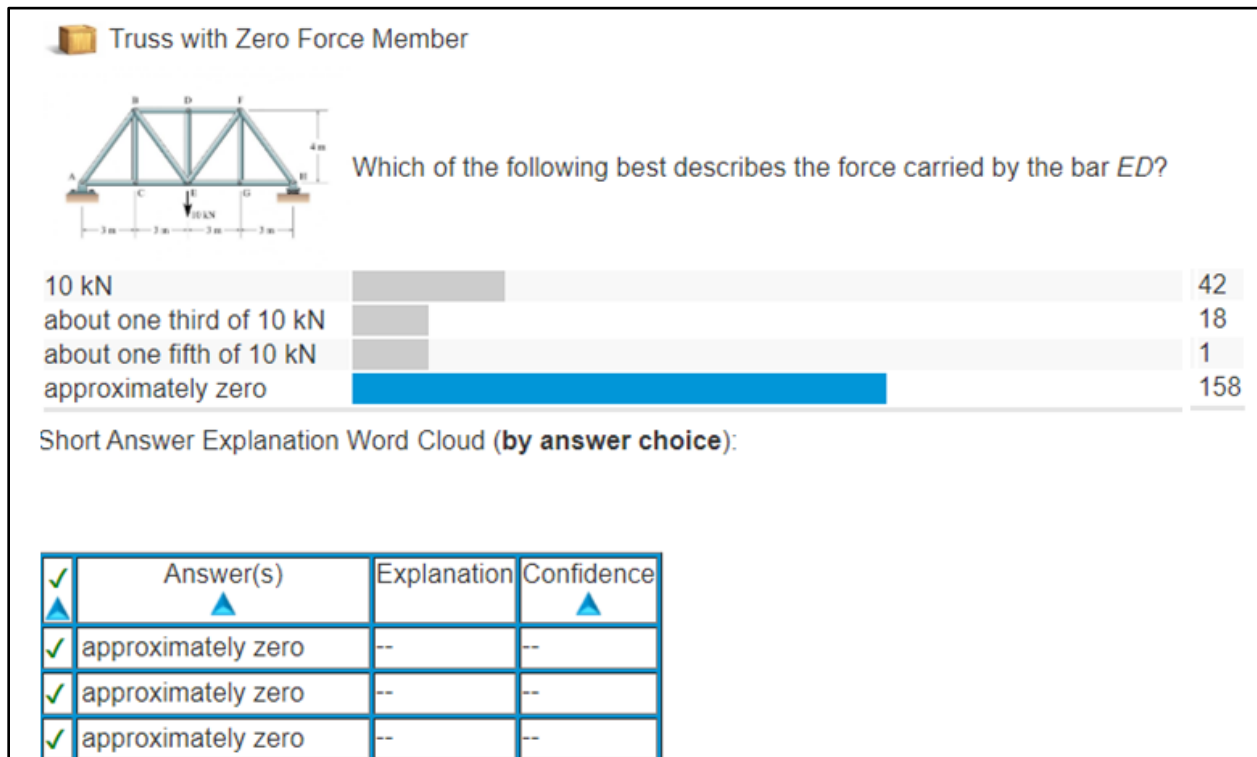

Figure 3. Sample of provided results in the Concept Warehouse (the list of individual responses is truncated).

Implementation:

In the Fall of 2019, the CW was deployed at Whatcom Community College and Oklahoma State University for Statics. Institutional characteristics are provided in Table 1. Whatcom

Community College had one course with an enrollment of 14 students (Cohort 1); Oklahoma State had two courses, one main offering and one honors, with enrollments of 274 and 69 (Cohorts 2 and 3, respectively). The two institutions varied greatly in enrollment, student major/interest, geographical location, and questions deployed. The instructor at Whatcom Community College, Eric Davishahl, had previous experience with concept-based learning exercises while the instructor at Oklahoma State, Carisa Ramming, was new to the exercises. In addition, the CW was introduced at different times during the duration of the course.

Between the two institutions, the CW was administered over 80 times with pre and post questions, in-class discussions, and homework. Of these deployments, the instructors identified four common questions that were used between all three cohorts. The question, number correct/incorrect, and modality are detailed in the Appendix.

Table 1: Institutional data, Fall 2019

	Whatcom Community College	Oklahoma State University
Enrollment	14	274
		69
Geographic location	Western US	Mid-South US
Deployed questions (including pre/post separately and homework)	60	22
Utilization in course duration	Full	Last 1/3
Instructor held prior experience with concept-based learning exercises	Y	N
Effectiveness survey administered to students	end of course	beginning of follow-on semester
Represented major/interest		
Aerospace Eng	Y	Y
Biosystems and Ag Eng		Y
Architecture/Architectural Eng		Y
Chemical Eng		Y
Civil/Environmental Eng	Y	Y
Construction Eng Tech		Y
Electrical Eng		Y
Electrical Eng Tech		Y
Fire Protection and Safety Eng Tech		Y
Industrial Engineering and Management		Y
Manufacturing Engineering	Y	
Mechanical Eng	Y	Y
Mechanical Eng Tech		Y

Early Results and Discussion:

Raw data of student performance on selected questions is provided in the Appendix. At the early stage of this work, no conclusive or statistically significant data is yet available as to the

“effectiveness” of the method. What is clear at this stage is that the CW is very useful as a platform to provide formative feedback to both students and instructors.

Students can receive feedback, for example, when ConcepTests are repolled one or more times. For example, an instructor might give a question at the beginning of a topic as a means of introducing an idea, and then repolling the ConcepTest later in the same class. Because results can be posted instantly (Figure 3), students can see how their answers compare with the class. This can then be used to foster a debate or discussion in which students can argue for their point of view and perhaps convince others. They can then see how their answers change after this or other process of deeper inquiry.

Instructors can also receive useful feedback. Obviously, the results of an initial poll give a window into what students initially grasp. Later, after repolling, the instructor can view the change in the students’ responses and reflect upon the effectiveness (or lack thereof) of additional comments or explanations. It is indeed humbling for an instructor to experience negligible or even “incorrect” changes among students’ responses after “the perfect explanation” has been given. Hopefully, this is part of a formative process in which instructors can better anticipate what students reasonably can – and cannot – absorb within a certain scope of conversation or allotted time.

Student Feedback:

All three cohorts were surveyed on their perception of the effectiveness of the CW. Cohort 1 was polled as the course was ending while Cohorts 2 and 3 were emailed a survey link at the beginning of the following semester. Cohort 1 had a 100% response rate with all 14 students while Cohorts 2 and 3 were emailed a survey link that yielded 116 responses, 34% of the enrollment. Cohort 1 responded to a prompt that included all teaching exercises utilized by the instructor while Cohorts 2 and 3 responded to the following prompt which asks about the CW specifically. Tables 2 and 3 chart the breakdown of the responses. Table 2 is a reflection of Cohort 1’s response to the CW, specifically with a rating of 4.1/5.0. Cohorts 2 and 3 were not polled separately and are shown combined in Table 3 with an overall rating of 2.8/5.0. In the survey link emailed to Cohorts 2 and 3, a comment box was included. Four students left comments.

Prompt:

“Rate the use of the Concept Warehouse learning activity on a scale of 1 (least effective) to 5 (most effective) with regard to how the activity contributed to your learning in statics last semester. A rating of 1 means you think this activity was not an effective use of your time in this class. A rating of 5 means you valued the activity as useful for learning the material and worth spending the time it required.”

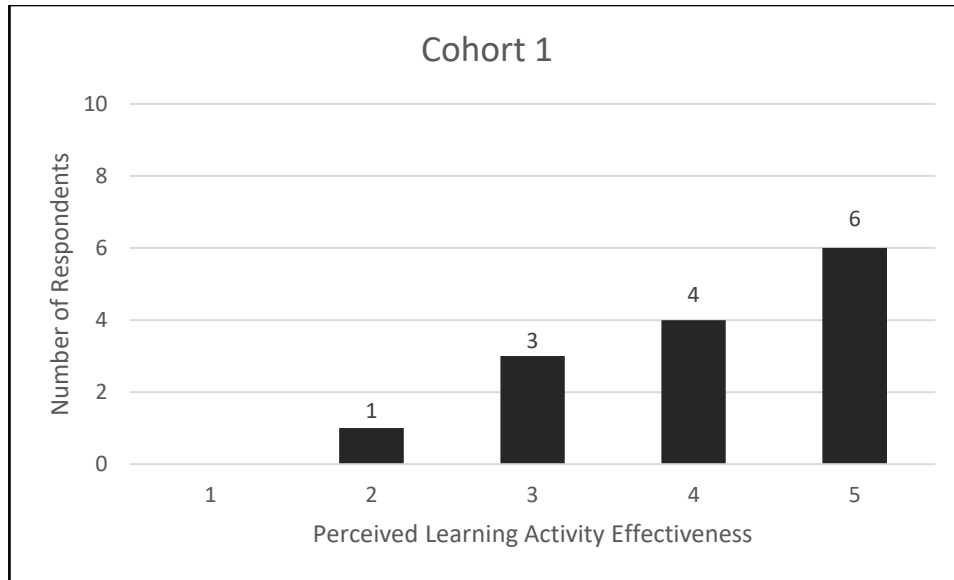

Table 2: Student Feedback on CW Effectiveness, Cohort 1

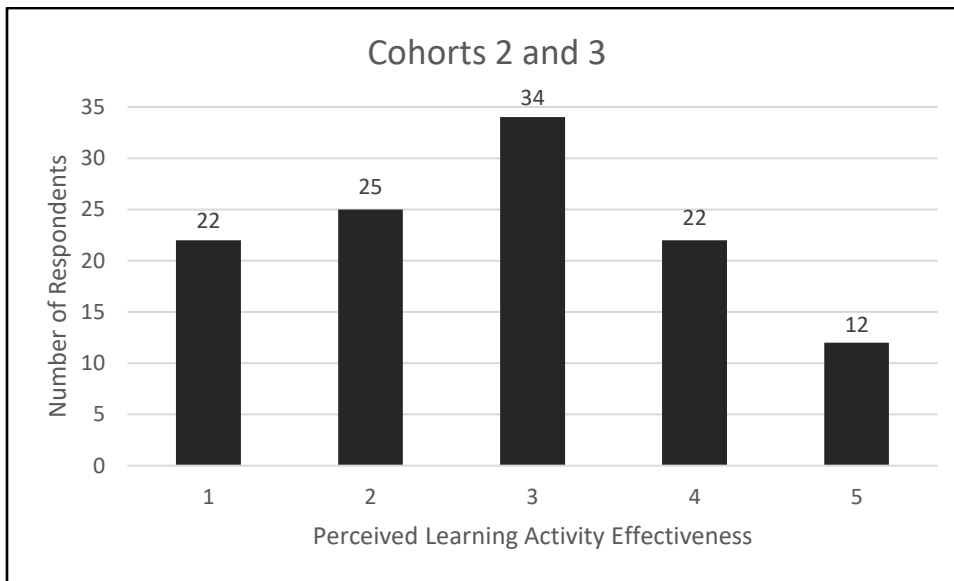

Table 3: Student Feedback on CW Effectiveness, Cohorts 2 and 3

Student Comments from Cohorts 2 and 3:

“Good”

“Would rate the idea of how Concept Warehouse targets points of confusion and clarified them as a 5 but I found the platform and format to [be] not very user friendly at all.”

“It was somewhat useful to learn how to identify zero-force members and 2-force members. Other concepts were harder to grasp from Concept Warehouse alone.”

“Didn’t always work, more time used getting it set up than using it.”

Instructor Observations and Lessons Learned:

The instructors compared experiences and student feedback to note some observations and lessons learned. The following points are particularly noteworthy:

- *Technology issues and glitches:* As with all technology, if any issues were encountered, students, teaching assistants, and faculty became easily flustered or frustrated.
- *Instructor confidence in deployment:* Similar to technology issues, if the instructor seemed cautious or hesitant, the students easily read this and mirrored the hesitation toward the new platform.
- *Technology overload:* If combining the use of the CW with additional technological applications such as iClicker, Top Hat, Learning Catalytics, etc., the students might feel like there are too many links and apps to manage during class.
- *Teaching assistant buy-in:* If the teaching assistants did not use a platform or are unfamiliar with the program, they are reluctant to “sell” the idea to the students. Properly exposing all individuals involved in the administration of the course could assist in the acceptance of new class activities and exercises.
- *Timing of implementation in class:* In the large public university classes, the CW was not introduced to Cohorts 2 and 3 until the last third of the course which caused confusion. The timing also coincided with a heavy part of the semester.

Future Goals and Implementation:

During the current semester, Spring of 2020, the CW is being deployed at Whatcom Community College, Oklahoma State University, and the University of Puerto Rico, Mayagüez. This work is in progress and is now being interrupted by the COVID-19 pandemic measures, although the CW will continue to be deployed in online instruction to the extent possible.

No significant analysis of student learning is currently available. The initial deployments at the 2-year and large public university were undertaken primarily to “beta-test” the CW for facility and accessibility, rather than to focus on using the CW to assess learning gains. Ideally, to test if use of the CW leads to learning gains, some baseline data should first be established, such as student performance on the CATS. Historical baseline data for CATS performance has been collected over several years at Whatcom and UPR Mayagüez, but has not yet been compared with emerging data from the use of the CW. In addition, other instructors at several other institutions are being recruited where baseline data is already or will be established.

Another possible way to assess the impact of the CW with learning is to compare performance on ConcepTests with other scores, such as exams. As a window into this, early data from Spring 2020 at UPR Mayagüez shows that the Pearson correlation coefficient between the composite ConcepTest performance (16 total deployments, including some which were polled more than once) and the score on the first exam is 0.53 ($n = 35$ students, $p < 0.01$). Similarly, at Whatcom Community College, the Pearson correlation coefficient for the aggregate ConcepTest performance (44 total deployments) is 0.62 ($n = 16$, $p < 0.01$). These results agree with general results from Goodwin, Self, and Widmann (2009) regarding a correspondence between student performance in Dynamics coursework and on the Dynamics Concept Inventory (DCI).

Although this might appear to be “promising”, it is unknown whether exposure to the ConcepTests drives performance, or whether inherent ability in statics manifests itself both in

exam scores and ConcepTest scores. A related question is whether practice with concept questions drives procedural understanding, and vice-versa.

	Whatcom Community College	Oklahoma State University	University of Puerto Rico, Mayagüez
Enrollment	17	180	42
		43	
Geographic location	Northwest US	Mid-South US	Southeast US
Deployed questions (including pre/post separately and homework)	TBD	TBD	TBD
Utilization in course duration	Full	Full	Full
Instructor held prior experience with concept-based learning exercises	Y	Y	Y
Effectiveness survey administered to students	end of course	end of course	end of course
Represented major/interest			
Aerospace Eng	Y	Y	
Biosystems and Ag Eng		Y	
Architecture/Architectural Eng		Y	
Chemical Eng		Y	Y
Civil/Environmental Eng	Y	Y	
Construction Eng Tech		Y	
Electrical Eng		Y	
Electrical Eng Tech		Y	
Fire Protection and Safety Eng Tech		Y	
Industrial Engineering and Management		Y	Y
Manufacturing Engineering	Y		
Mechanical Eng	Y	Y	Y
Mechanical Eng Tech		Y	

Table 4: Institutional data, Spring 2020

Conclusions:

During the last year, the project team has made significant progress populating the CW with 140 concept questions for statics, and this number is expected to reach 200 by the time of the (now virtual) 2020 Annual Conference & Exposition. This sizeable bank provides excellent potential for concept instruction to be scaled up and used frequently, owing to the ability to cover many concepts in a manner that does not compromise the security of the instrument. Early results show students are reasonably engaged as a result of using the platform, and this experience is likely to increase as instructors become more agile with deploying it. In terms of learning results, no statistically significant results are yet available, but the data point to an immediate formative use for both students and instructors alike.

Acknowledgement

This material is based upon work supported by the National Science Foundation under Grant Nos. 1821638 and 1821445.

Bibliography

- Beatty, Ian D., William J. Gerace, William J. Leonard, and Robert J. Dufresne. 2006. "Designing Effective Questions for Classroom Response System Teaching." *American Journal of Physics* 74 (1): 31–39. <https://doi.org/10.1119/1.2121753>.
- Clement, John. 1982. "Students' Preconceptions in Introductory Mechanics." *American Journal of Physics* 50 (1): 66–71. <https://doi.org/10.1119/1.12989>.
- Freeman, S., S. L. Eddy, M. McDonough, M. K. Smith, N. Okoroafor, H. Jordt, and M. P. Wenderoth. 2014. "Active Learning Increases Student Performance in Science, Engineering, and Mathematics." *Proceedings of the National Academy of Sciences* 111 (23): 8410–15. <https://doi.org/10.1073/pnas.1319030111>.
- Goodwin, L., Self, B.P. and Widmann, J. 2009. "Is There a Correlation Between Conceptual Understanding and Procedural Knowledge in Introductory Dynamics?" *Proceedings of the 2009 American Society for Engineering Education Pacific Southwest Regional Conference*, San Diego, CA.
- Haak, David C, Janneke HilleRisLambers, Emile Pitre, and Scott Freeman. 2011. "Increased Structure and Active Learning Reduce the Achievement Gap in Introductory Biology." *Science* 332 (6034): 1213–16. <https://doi.org/10.1126/science.1204820>.
- Halloun, Ibrahim Abou, and David Hestenes. 1985a. "Common Sense Concepts about Motion." *American Journal of Physics* 53 (11): 1056–65. <https://doi.org/10.1119/1.14031>.
- . 1985b. "The Initial Knowledge State of College Physics Students." *American Journal of Physics* 53 (11): 1043–55. <https://doi.org/10.1119/1.14030>.
- Koretsky, Milo, Susan Nolen, Brian Self, Christopher Papadopoulos, Jim Widmann, Michael Prince, and Dominic Dal Bello. 2019. "For Systematic Development of Conceptests for Active Learning." In *Proceedings EDULEARN 19 (11th Annual International Conference on Education and New Learning Technologies)*, 1:8882–92. <https://doi.org/10.21125/edulearn.2019.2205>.
- Mazur, E. 1992. "Qualitative vs. Quantitative Thinking: Are We Teaching the Right Thing?" *Optics & Photonics News* 3 (February): 38.
- McDermott, L.C. 1984. "Research on Conceptual Understanding in Mechanics." *Physics Today* 37 (July): 24–32. <https://doi.org/10.1063/1.2916318>.
- National Academies of Science, Engineering, and Medicine. 2011. *Expanding Underrepresented Minority Participation: America's Science and Technology Talent at the Crossroads*. Expanding Underrepresented Minority Participation: America's Science and Technology Talent at the Crossroads. The National Academies Press. <https://doi.org/10.17226/12984>.

Steif, P.S., J.A. Dantzler. 2005. "A Statics Concept Inventory: Development and Psychometric Analysis." *Journal of Engineering Education* 94 (4): 363-371.
<https://doi.org/10.1002/j.2168-9830.2005.tb00864.x>

Appendix

Question 1:



Figure 4: Static Friction Acting on a Box Subject to Lateral Force

Q. You are holding a box of books with flat hands. If you press harder, what happens to the friction force applied by your hands onto the sides of the box?

- A. It increases
- B. It decreases
- C. It remains the same
- D. Not enough information to determine

Table 5: Results from question 1

Cohort	Correct	Incorrect	Total	Modality	
				In-class	Homework
1	9	3	12	x	
2	37	21	58	x	
3 - pre	71	114	185	x	
3 - post	81	98	179	x	

Question 2:

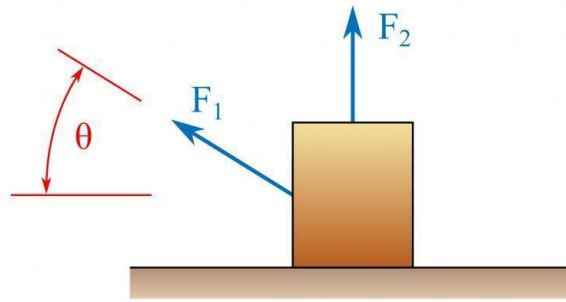

Figure 5: Friction 2

Q. The box rests in static equilibrium on the rough floor and is subjected to the forces F_1 and F_2 as shown. The force F_1 is increased by 10%, but the box does not accelerate. What happens to the friction force between the box and the floor?

- A. The friction force increases
- B. The friction force stays the same
- C. The friction force decreases
- D. There is not enough information to answer this question

Table 6: Results from question 2

Cohort	Correct	Incorrect	Total	Modality	
				In-class	Homework
1 - pre	10	2	12		
1 - post	12	0	12		
2 - pre	34	25	59	x	
2 - post	39	19	58	x	
3	87	97	184	x	

Question 3:

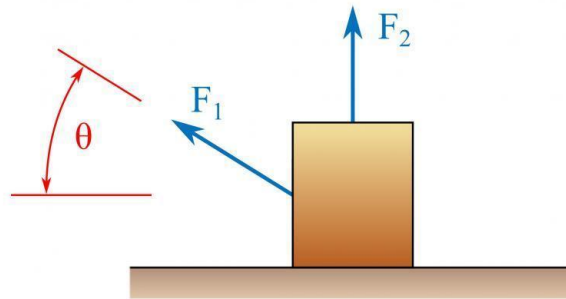

Figure 6: Friction 4

Q. The box rests in static equilibrium on the rough floor and is subjected to the forces F_1 and F_2 as shown. The mass of the box is increased by 10%, but the box does not accelerate. What happens to the friction force between the box and the floor?

- A. The friction force increases
- B. The friction force stays the same
- C. The friction force decreases
- D. There is not enough information to answer this question

Table 7: Results from question 3

Cohort	Correct	Incorrect	Total	Modality	
				In-class	Homework
1 - pre	5	7	12		
1 - post	8	3	11		
2	8	55	63	x	
3	36	151	187	x	

Question 4:

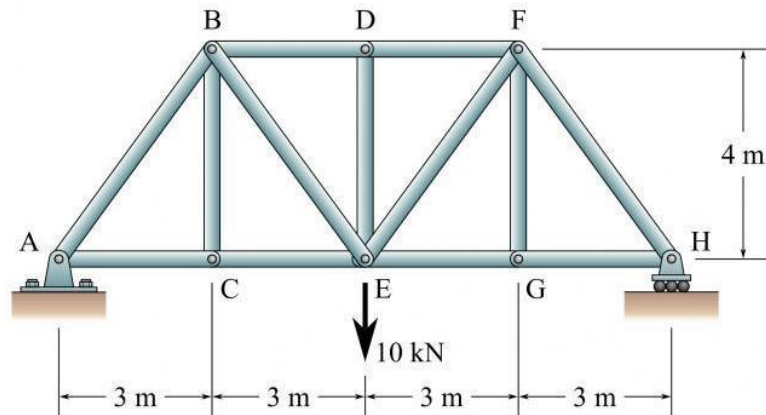

Figure 7: Truss with two-force member

Q. Which of the following best describes the force carried by the bar ED?

- A. 10 kN
- B. About one third of 10 kN
- C. About one fifth of 10 kN
- D. Approximately zero

Table 8: Results from question 4

Cohort	Correct	Incorrect	Total	Modality	
				In-class	Homework
1 – pre	4	9	13	x	
1 – post 1	6	8	14	x	
1 – post 2	10	3	13	x	
2	53	11	64	x	
3	156	60	216	x	